

マルチボアツールリングシステム リダクション

Reduction

- マルチボアシステムでの結合部サイズ変更時に使用します。
For reduction in the size of connecting part.

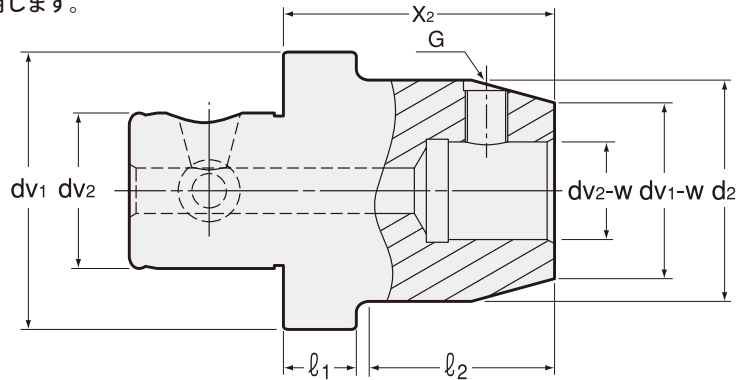

商品コード Code	型式 Model	ボーリングヘッド加工範囲 Boring dia.	X2	dv1	dv2	l1	l2	d2	dv1-W	dv2-W	G	kg	—
5040 02218130	RE14 -1811 -30	20 ~ 24	30	25	14	9	20	19.5	19.5	11	C5-1	0.2	7,000
5040 02222130	-2211 -30	24 ~ 29	30	25	14	9	20	22	22	11	C5-2	0.2	7,000
5040 02322112	RE18 -2211 -12	20 ~ 24 24 ~ 29	12	32	18	11.5	—	22	22	11	C5-2	0.2	7,000
5040 02325230	-2514 -30	29 ~ 37 36 ~ 44	30	32	18	9	20	25	25	14	C8-1	0.4	8,000
5040 02422112	RE22 -2211 -12	20 ~ 24 24 ~ 29	12	40	22	11.5	—	22	22	11	C5-3	0.4	7,000
5040 02425230	-2514 -30	29 ~ 37 36 ~ 44	30	40	22	9	20	25	25	14	C8-1	0.4	8,000
5040 02440330	-4018 -30	43 ~ 54	30	40	22	—	—	40	32	18	C8-3	0.5	8,000
5040 02518154	RE28 -1811 -54	20 ~ 24 24 ~ 29	54	50	28	13	40	18	18	11	C5-1	0.4	9,000
5040 02522114	-2211 -14	20 ~ 24 24 ~ 29	14	50	28	13.5	—	22	22	11	C5-2	0.3	7,000
5040 02522154	-54	24 ~ 29	54	50	28	13	40	22	22	11	C5-2	0.4	9,000
5040 02525214	-2514 -14	29 ~ 37 36 ~ 44	14	50	28	13	—	25	25	14	C8-3	0.4	7,000
5040 02525259	-59	29 ~ 37	59	50	28	13	44	25	25	14	C8-1	0.4	9,000
5040 02532259	-3214 -59	36 ~ 44	59	50	28	13	44	32	25	14	C8-2	0.7	9,000
5040 02532211	-119	36 ~ 44	119	50	28	13	104	32	25	14	C8-2	0.9	10,000
5040 02536211	-3614 -119	38 ~ 44	119	50	28	13	104	36	25	14	C8-2	1.1	10,000
5040 02540349	-4018 -49	43 ~ 54	49	50	28	13	34	40	32	18	C8-3	1.0	9,000
5040 02540310	-109	43 ~ 54	109	50	28	13	94	40	32	18	C8-3	1.1	10,000
5040 02546310	-4618 -109	48 ~ 54	109	50	28	13	94	46	32	18	C8-3	1.4	10,000
5040 02550440	-5022 -40	53 ~ 66	40	50	28	—	—	50	40	22	C10-2	1.2	9,000
5040 02550410	-100	53 ~ 66	100	50	28	—	—	50	40	22	C10-2	1.4	10,000
5040 02563650	-6336 -50	82 ~ 103	50	63	28	—	—	63	63	36	C16-1	1.0	10,000
5040 02618154	RE36 -1811 -54	20 ~ 24	54	63	36	13	40	18	18	11	C5-1	0.6	9,000
5040 02622114	-2211 -14	20 ~ 24 24 ~ 29	14	63	36	13.5	—	22	22	11	C5-3	0.5	7,000
5040 02622154	-54	24 ~ 29	54	63	36	13	40	22	22	14	C5-2	0.6	9,000
5040 02625214	-2514 -14	29 ~ 37 36 ~ 44	14	63	36	13	—	25	25	14	C8-3	0.6	7,000
5040 02625259	-59	29 ~ 37	59	63	36	13	44	25	25	14	C8-1	0.7	9,000
5040 02632259	-3214 -59	36 ~ 44	59	63	36	13	44	32	25	14	C8-2	0.8	9,000
5040 02632211	-119	36 ~ 44	119	63	36	13	104	32	25	14	C8-2	1.2	10,000
5040 02636211	-3614 -119	38 ~ 44	119	63	36	13	104	36	25	14	C8-2	1.4	10,000
5040 02640349	-4018 -49	43 ~ 54	49	63	36	13	34	40	32	18	C8-3	0.8	9,000
5040 02640310	-109	43 ~ 54	109	63	36	13	94	40	32	18	C8-3	1.4	10,000
5040 02646310	-4618 -109	48 ~ 54	109	63	36	13	94	46	32	18	C8-3	1.7	10,000
5040 02650440	-5022 -40	53 ~ 66	40	63	36	13	25	50	40	22	C10-2	0.9	9,000
5040 02650410	-100	53 ~ 66	100	63	36	13	85	50	40	22	C10-2	1.8	10,000
5040 02650415	-150	53 ~ 66	150	63	36	13	135	50	40	22	C10-2	2.6	12,000
5040 02650540	-5028 -40	65 ~ 83	40	63	36	13	25	50	50	28	C12-1	0.9	10,000
5040 02650510	-100	65 ~ 83	100	63	36	13	85	50	50	28	C12-1	1.8	11,000
5040 02663540	-6328 -40	65 ~ 83	40	63	36	—	—	63	50	28	C12-1	1.0	10,000
5040 02663510	-100	65 ~ 83	100	63	36	—	—	63	50	28	C12-1	2.4	11,000
5040 02680650	-8036 -50	82 ~ 205	50	80	36	—	—	80	63	36	C16-2	1.7	10,000

ご注文例 Ordering Example

RE14 - 18 11 - 30

ジョイント部インローサイズ d2 | X2
Centering location size
先端側ジョイント部
Joint part